

Tiger LED ShopFitter 30W Ceiling Light

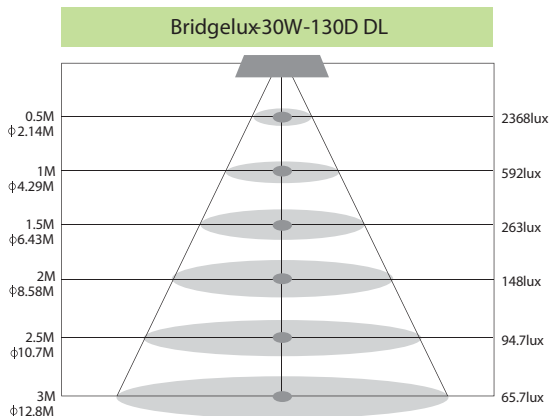

Comparable to 150W metal halide.
Saves more than 60% by replacing metal halides.
Better light quality for retail and commercial applications.
Adjustable to direct light where it is needed.

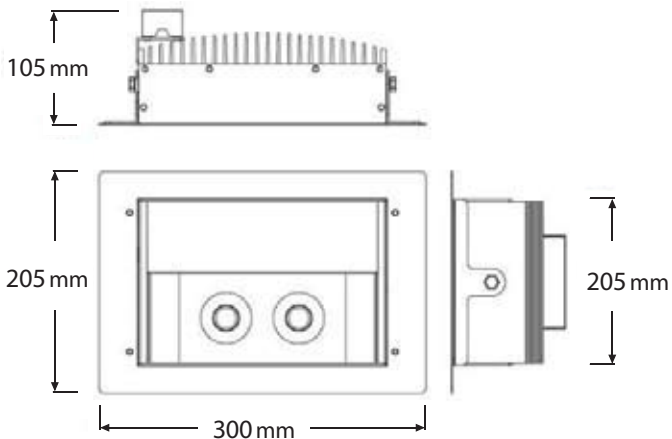

Ideal for retrofitting existing retail and commercial installations

- Helps meet reduced wattage per square metre targets in retail.
- LED delivers over 60% energy savings compared to halogen (eg AR111).

Far greater energy efficiency than halogen lamps

- Reduces carbon footprint by more than 60%.
- No excessive heat output from LED.

Exceptional light creates ambience in retail boutiques

- Brings product displays to life.

Highest quality product available

- Quality Bridgelux LED chips.
- Fully accredited: ETL, CE, FCC, LVD, Laser Testing.
- Top class presentation and finish.

Dependable performance

- Lifespan 50,000 hours.

Safer for the office and the home environment

- 0% mercury, 0% toxic material.

Applications:

- Commercial and office lighting.
- Retail stores and boutiques.
- For use where premium quality and longevity is important.

Power consumption	30W
Input voltage	100-240V AC
Beam angle	130°
LED chipset	Bridgelux
Lens	Optics PMMA
CRI	80
Colour temperature	Daylight 5000-6500K
Lumen output max	Daylight 2500lm
Product lifespan	50,000+ hours
Weight	2kg
Operating temperature	-40° to +50°C
Environment	Suitable for damp environments, 0-95% non-condensing
Certification	ETL, CE, FCC, LVD, Laser testing
Warranty	2 years

bellingensolar



Call 1300 558 043 or 6655 9266
 1-3 Church Street Bellingen
www.bellingensolar.com.au